

ZAXIS-7 series

HITACHI

Reliable solutions

# ZAXIS210/240N



## HYDRAULIC EXCAVATOR

Model code : ZX210LC-7 / ZX210LCN-7  
Engine rated power : 128.4 kW (ISO 14396) /  
122 kW (ISO 9249)  
Operating weight : 21 900 – 23 900 kg  
Bucket ISO heaped : 0.51 – 1.20 m<sup>3</sup>

Model code : ZX240N-7  
Engine rated power : 128.4 kW (ISO 14396) /  
122 kW (ISO 9249)  
Operating weight : 22 700 – 23 300 kg  
Bucket ISO heaped : 0.51 – 1.20 m<sup>3</sup>

# You're in control

You're at the heart of Hitachi's design for its latest range of excavators. To continuously improve on previous generation machines we've focused on enhancing your experience in the cab as an operator.

We've considered the challenges you face as the owner of a successful business. And we've zoomed in on the ways in which we can support you over the life cycle of your machine.

By putting you at the heart of the Zaxis-7 range, we invite you to take control – over your workspace and your fleet. And by working in partnership, we will help you to create your vision.





# Inside



In control of your business

---

**8.** Improve your profit



In control of your comfort

---

**10.** Feel the difference



In control of your environment

---

**12.** Increase your safety



In control of your assets

---

**14.** Boost your uptime



In control of your fleet

---

**16.** Manage your machine



In control of your uptime

---

**18.** Protect your investment



In control of your performance

---

**20.** Get more from your machine

# Complete control

The new Zaxis-7 range of medium excavators puts you firmly in control, so you can feel assured of your machine's performance, and supported by the technological expertise and services that Hitachi provides.



The expanded cab interior provides a more comfortable working environment.



Sensors monitor oil continuously and contribute to preventative maintenance, helping to reduce downtime.



ConSite Pocket app allows you to manage and monitor your fleet remotely.



Options such as Hitachi ground engaging tools enable you to enhance the performance of your excavator.



Improved access to components ensures maintenance is quick and easy.





Integrated console and seat suspension gives a greater sense of control, and helps to reduce fatigue.

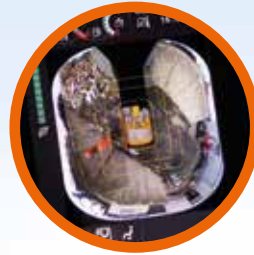

Visibility of the job site is excellent thanks to the Aerial Angle camera system and new LCD monitor.



The durable undercarriage of the ZX240N-7 is easy to manoeuvre on rocky terrain.



The improved TRIAS III hydraulic system reduces fuel consumption and increases efficiency.

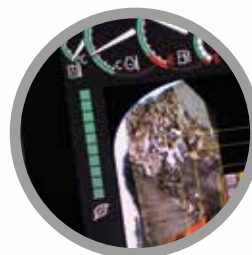

The ECO gauge on the monitor indicates how to lower fuel consumption and reduce costs.



1

2

16

4

3

5

15

13

14

6

7

8

9

11

10

12

# Control zone

Enhanced comfort and safety features are at your fingertips in the refined cab of Zaxis-7 excavators, giving you the power to perform productively, with ease and reduced fatigue.

- 1 **Increased sweeping area of parallel link wiper** enhances visibility in difficult working conditions.
- 2 **Air conditioning and audio** are easily controlled via the monitor.
- 3 **Low-reflective colour 8" LCD monitor** is easy to view and navigate.
- 4 **USB socket and smartphone holder** helps you stay connected.
- 5 **Drinks holder** is easy to detach for cleaning.
- 6 **Additional joystick controls** for effortless operation.
- 7 **Ergonomic design** gives you convenient access to controls.
- 8 **Bluetooth®** for hands-free calls and **DAB+** radio for music while you work.
- 9 **Multifunctional control panel** makes operation easier.
- 10 **Improved sound isolation** makes this one of the quietest cabs in the market.
- 11 **User-friendly storage space** keeps your workspace tidy and clutter-free.
- 12 **Coat hooks** take care of your personal belongings.
- 13 **One-touch adjustment lever for console** so you can work comfortably in the optimum position.
- 14 **Integrated console and seat suspension** gives a greater sense of control and helps to reduce fatigue.
- 15 **Increased legroom** creates a more spacious cab.
- 16 **Optimal pedal layout** helps to reduce fatigue.



Operation is easy with ergonomically designed controls and switches.



Bluetooth® connection for hands-free calls while you work.

In control of your business



# Improve your profit

The success of your business depends on the reliability and efficiency of your construction machinery. With Hitachi's latest Zaxis-7 medium excavators, you can count on the highest quality, the ultimate in operating comfort and reduced running costs – all of which will have a positive impact on your bottom line.

You can look forward to increasing your profits thanks to the impressive fuel economy of these Stage-V compliant machines. The stunning new-look ZX210-7 and ZX240N-7 deliver up to 11% less fuel consumption than the previous models.

Hitachi's industry-leading hydraulic system, the new TRIAS III, ensures that this incredible level of performance is achieved in every application. Its superior efficiency excels while loading or during heavy digging operations.

Your operators can also control fuel efficiency – and reduce costs – by using the all-new ECO gauge. This is clearly visible on the multifunctional colour LCD eight-inch monitor.

In addition, you can boost your profits by working on a wider range of projects thanks to the excellent versatility of Zaxis-7 excavators. Choose from a variety of specifications to meet the requirements of any job site, including mono and 2-piece boom. The long undercarriage on the ZX210LC-7 provides optimal stability and the narrow undercarriage (ZX210LCN-7 and ZX240N-7) models can be easily transported. In addition, the ZX240N-7 is easy to manoeuvre on rocky terrain. Different attachments are quickly changed using the enhanced attachment support system on the monitor.

With a simple adjustment to suit your operator's preference and job site requirements, you can fine-tune your machine for optimum productivity – while still reducing fuel consumption. Special application versions of these models can be used for specific tasks, such as slope finishing and dredging (super long front).



A fuel saving of up to 11% is achieved with the TRIAS III hydraulic system.





TRIAS III provides optimum operating efficiency on every job site.

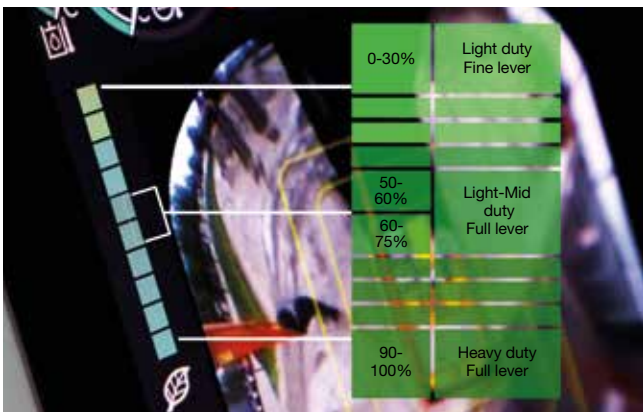

The ECO gauge helps to deliver better fuel consumption.



The attachment support system enables increased versatility.



You're in control with a spacious, tidy and enjoyable working environment.



The cab has ample space for your belongings.



The LCD monitor is easy to view with hi-res anti-glare screen.



In control of your comfort



# Feel the difference

Hitachi's redesigned, state-of-the-art Zaxis-7 excavator cab gives you the perfect working environment. The ultra-spacious ZX210-7 and ZX240N-7 offer you an industry-leading, first-class cab with the ultimate in comfort and quality, as well as some of the lowest noise levels in the market and 16% less vibration than the previous generation.

Feel the difference with the synchronised motion of the seat and console, designed to ensure you feel less tired at the end of the working day. Stretch out in the most spacious Hitachi cab yet, with improved pedal layout and ample head clearance. And sit comfortably thanks to the easily adjustable console height with three positions to choose from.

Easy operation comes from the new ergonomic design of the console and switches, and convenient access to controls. You can navigate quickly through the menu on the 8" LCD monitor with the multifunctional controller. The hi-res anti-glare screen is also easier to view, and the refreshed layout offers a clear display and desirable functionality – such as air conditioning, DAB+ radio and Bluetooth®.

With more storage for your personal belongings, such as your coat, smartphone and drink, you'll feel instantly relaxed and ready for your shift. Added practical functions to the joysticks, such as wiper, engine idle and audio mute controls, will make your working day effortless and enjoyable.



Ergonomic multifunctional control panel provides easy access.



# Increase your safety

Your ability to work safely is vital, not only for your own wellbeing, but also for the successful completion of any project. To protect yourself and your machine from potential hazards, the new Hitachi Zaxis-7 excavators give you a superior view of your surroundings, so you can see the job site from all angles.

The visibility you enjoy from the cab includes an exceptional 270-degree bird's-eye view with the Aerial Angle camera system. You can choose from six image options to view the machine's immediate environment, which enables you to control your own safety – as well as that of those around you.

To help you to work more confidently and efficiently, even in the most challenging of conditions, Zaxis-7 excavators are fitted with some impressive new features. From the LED work lights and the windscreen wiper with an increased sweeping area, to the large reflective strips on the counterweight and optional roller sunshades, you'll have the visibility you need when it matters most.

Attention to detail is also fundamental to a safe working environment – and the repositioning of the pilot shutoff lever is a perfect example. It is now within easy reach to prevent any unintentional actions.



Wider wiper design provides greater visibility.



Control your safety with the 270-degree view Aerial Angle camera system.



Choose between different image layouts to suit your working environment.



LED work lights improve visibility in challenging conditions.



Designed for durability and easy maintenance, Zaxis-7 excavators increase uptime and reduce the total cost of ownership.



Durable after-treatment system prevents downtime.



Maintenance is easy at ground level.



New layout provides convenient access to all filters.



In control of your assets



# Boost your uptime

Completing a project on time and on budget depends on the ability of your construction equipment to perform all day, every day. That's why Hitachi owners have profited from generations of ultra-reliable and durable machinery – and the Zaxis-7 range is no exception.

The latest Hitachi medium excavators have been built to last, so that you can remain in complete control of your assets. They have been tested rigorously and continuously at dedicated facilities in Japan with the goal of significantly boosting your uptime.

As a result, a wide range of durable new components have been fitted to the latest Stage-V compliant machines – even down to the detail of the rigidity of the door hinges. Now standard on our Zaxis-7 range is a high-performance hydraulic filter to capture any dust in the hydraulic oil and help to reduce running costs.

Downtime is prevented by the durable after-treatment system, and also minimised by the priority given to easy maintenance and cleaning – saving you time and money. Peace of mind comes from such features as the two-way disconnect switch. This makes it possible to shut down power without resetting data on the monitor and prevents the battery from discharging during welding.



# Manage your machine

Hitachi offers a wide range of after-sales services to help you feel in total control of your fleet and workload. These initiatives give you access to vital data and tools to manage your machine.

Remote monitoring systems Owner's Site and ConSite send operational data daily via GPRS or satellite from your excavator to [www.globaleservice.com](http://www.globaleservice.com). This includes: ratios of operating hours to enhance efficiency; fuel consumption to manage running costs; and machine location for planning purposes. ConSite summarises the information in a monthly email.

The ConSite Pocket App sends you real-time alerts for issues arising with your machine. You'll receive recommendations on what to do and step-by-step help guides. The app also enables you to see the location of your fleet.

A unique innovation continuously monitors the quality of engine and hydraulic oil, 24/7. Data is transmitted daily via two oil sensors to Global e-Service. These detect if the oil quality has deteriorated, due to contamination or low viscosity. If this happens, you and your authorised Hitachi dealer will receive an alert.

This innovative feature provides accurate estimations of when oil changes are required. It reduces maintenance and unscheduled downtime, and gives you peace of mind thanks to scheduled servicing and ultimately a higher resale value.



The unique oil sensor reduces maintenance and downtime.



A wide range of data on Global e-Service enhances efficiency.



The alerts on the ConSite Pocket App provide real-time information.





Hitachi offers a wide range of after-sales services for planning maintenance and managing running costs.



Minimise downtime with Hitachi Genuine Parts.



HELP extended warranties and service contracts provide optimal performance.



Hitachi Premium Rental enables you to pay as you earn.



Hitachi provides the highest level of technical support.



In control of your uptime



# Protect your investment

If your machine will be working in severe conditions, or you want to minimise repair costs, you can take advantage of a unique extended warranty programme called HELP (Hitachi Extended Life Program) and comprehensive service contracts. These can help to optimise performance, reduce downtime and ensure a higher resale value.

We apply the same technological expertise to our wide range of high-quality parts as we do our machines. As a result, you can minimise unscheduled downtime and ensure maximum availability.

The parts range includes Hitachi Genuine Parts, Performance Parts, filters, undercarriages, and remanufactured components. We also offer ground engaging tools and buckets, which have been manufactured to the same exacting standards.

As your business grows, you may need to extend your fleet to meet the demands of new contracts. Why not try before you buy with the Hitachi Premium Rental programme? This gives you immediate access to Zaxis-7 medium excavators for a period of one month to a year.

Along with the reliability, quality and service you would expect from the Hitachi brand, Hitachi Premium Rental offers flexible contracts and fixed costs that make it easier for you to budget.

In control of your performance



# GET more from your machine

Designed to work in perfect harmony with your machine, Hitachi's durable hydraulic breakers, buckets and ground engaging tools (GET) will increase your profit by maximising productivity and uptime. Manufactured to the same high standards as all Hitachi construction equipment, they offer unrivalled reliability and exceptional performance.

## Buckets

You can increase the versatility of your excavator by choosing the right bucket for the job. For loading light materials or heavy-duty work, Hitachi buckets can be customised to meet your needs. You have a wide range of options to choose from – including GD, HD and XHD buckets with different capacities and widths – and quick coupler connections such as CW, pin grabber and S-coupling are also available.

## Ground engaging tools

You can enhance the digging power and productivity of your excavator with Hitachi GET. Quick and safe to install and replace, they fit precisely to your attachments and can be tailored to suit the task. Using Hitachi GET can reduce your maintenance costs and downtime, lower fuel consumption and enhance the overall performance of your machine.

## Breakers

High-performance hydraulic breakers – approved by Hitachi – are perfectly suited to medium excavators. They are easy to maintain and user-friendly, and their high-quality materials ensure a long lifetime. This means reduced maintenance costs, fewer replacement parts and minimal downtime.



Hitachi buckets, GET and breakers are manufactured to the same high standards as all Hitachi construction equipment.



Hitachi buckets can be customised to suit the application.



Hitachi breakers are lightweight with high impact energy.



Hitachi GET include self-sharpening teeth and reliable adapters to ensure a precise fit.



EH dump trucks and EX ultra-large excavators



Special application excavators



Create your vision

---

# In control of your world

When you take delivery of a Hitachi machine, you become part of the latest generation of a global family. With a 50-year heritage in designing hydraulic excavators, and a reputation as the industry's leading mining machine manufacturer, the Hitachi network will give you access to a range of exceptional construction equipment.

Like the new Zaxis-7 excavators, Hitachi wheel loaders, rigid dump trucks, and special application machines incorporate advanced technology and pioneering expertise. This is inspired by parent company Hitachi Ltd, which was founded on the philosophy to make a positive contribution to society through technology.

In addition to the latest products made at state-of-the-art facilities and built to the highest quality standards, you'll have the support of our experienced engineers and dedicated dealer personnel. You'll also benefit from market-leading services and initiatives, such as Premium Rental and Premium Used, which have been created to enhance your experience as a Hitachi customer.

Whatever vision you wish to create, Hitachi has the product, people, solutions and services you need to make it become a reality – and empower you to take control of your world.



ZW wheel loaders



Mini excavators

# SPECIFICATIONS

## ENGINE

Model .....	Isuzu 4HK1
Type .....	4-cycle water-cooled, common rail direct injection
Aspiration .....	Variable geometry turbocharged, intercooled, cooled EGR
Aftertreatment .....	DOC+CSF+SCR system
No. of cylinders .....	4
Rated power	
ISO 14396 : 2002 .....	128.4 kW at 2 000 min <sup>-1</sup>
ISO 9249 : 2007 .....	122 kW at 2 000 min <sup>-1</sup>
Maximum torque .....	670 Nm at 1 600 min <sup>-1</sup>
Piston displacement .....	5.193 L
Bore and stroke .....	115 mm x 125 mm
Batteries .....	2 x 12 V / 126 Ah

## HYDRAULIC SYSTEM

### Hydraulic Pumps

Main pumps .....	3 variable displacement axial piston pumps
Maximum oil flow .....	2 x 212 L/min 1 x 184 L/min
Pilot pump .....	1 gear pump
Maximum oil flow .....	33.7 L/min

### Hydraulic Motors

Travel .....	2 variable displacement axial piston motors
Swing .....	1 axial piston motor

### Relief Valve Settings

Implement circuit .....	34.3 MPa
Swing circuit .....	32.4 MPa
Travel circuit .....	34.3 MPa
Pilot circuit .....	3.9 MPa
Power boost .....	38.0 MPa

### Hydraulic Cylinders

#### ZX210LC-7 / ZX210LCN-7

#### ZX240N-7

Unit: mm

	Quantity	Bore	Rod diameter
Boom	2	120	85
Arm	1	135	95
Bucket	1	115	80
Positioning *1	1	150	100

\*1 : For 2-piece boom

## UPPERSTRUCTURE

### Revolving Frame

D-section frame for resistance to deformation.

### Swing Device

Axial piston motor with planetary reduction gear is bathed in oil. Swing circle is single-row. Swing parking brake is spring-set/hydraulic-released disc type.

Swing speed .....	11.4 min <sup>-1</sup>
Swing torque .....	68 kNm

## UNDERCARRIAGE

### Tracks

Tractor-type undercarriage. Welded track frame using selected materials. Side frame welded to track frame. Lubricated track rollers, idlers, and sprockets with floating seals.

Track shoes with triple grousers made of induction-hardened rolled alloy. Heat-treated connecting pins with dirt seals. Hydraulic (grease) track adjusters with shock-absorbing recoil springs.

### Numbers of Rollers and Shoes on Each Side

	ZX210LC-7 / ZX210LCN-7	ZX240N-7
Upper rollers	2	2
Lower rollers	8	8
Track shoes	49	47
Track guards	2	2

### Travel Device

Each track driven by 2-speed axial piston motor. Parking brake is spring-set/hydraulic-released disc type. Automatic transmission system: High-Low.

Travel speeds .....	High : 0 to 5.5 km/h Low : 0 to 3.5 km/h
---------------------	---------------------------------------------

Maximum traction force ... 203 kN

Gradeability .....

70% (35 degree) continuous

## ENVIRONMENT

### Engine Emissions

EU Stage V

### Sounds Level

#### ZX210LC-7 / ZX210LCN-7

#### ZX240N-7

Sound level in cab according to ISO 6396 : 2008 ..... LpA 70 dB(A)

External sound level according to ISO 6395 : 2008 and

EU Directive 2000/14/EC ..... LwA 101 dB(A) / LwA 102 dB(A)

### Air Conditioning System

The air conditioning system contains fluorinated greenhouse gases.

Refrigerant type: HFC-134a, GWP: 1430, Amount: 0.85 kg, CO<sub>2</sub>e: 1.22 ton.

## SERVICE REFILL CAPACITIES

Unit: L

	ZX210LC-7 / ZX210LCN-7	ZX240N-7
Fuel tank	400.0 / 300.0	300.0
Engine coolant	28.0	28.0
Engine oil	23.0	23.0
Swing device	6.9	6.9
Travel device (each side)	6.8	6.8
Hydraulic system	240.0 / 220.0	220.0
Hydraulic oil tank	135.0 / 120.0	120.0
DEF/AdBlue® tank	57.0 / 35.0	35.0



## WEIGHTS AND GROUND PRESSURE

### Operating Weight and Ground Pressure

			ZX210LC-7*1				ZX210LCN-7*2				ZX240N-7*3			
Boom type			Monoblock		2-Piece		Monoblock		2-Piece		Monoblock		2-Piece	
Shoe type	Shoe width (mm)	Arm length (m)	kg	kPa	kg	kPa	kg	kPa	kg	kPa	kg	kPa	kg	kPa
Triple grouser	500	2.42	–	–	–	–	21 900	55	22 400	56	–	–	–	–
		2.91	–	–	–	–	22 000	55	22 500	56	–	–	–	–
	550	2.42	–	–	–	–	–	–	–	–	22 700	54.0	23 200	55.0
		2.91	–	–	–	–	–	–	–	–	22 800	54.0	23 300	56.0
	600	2.42	22 500	47	23 000	48	22 200	46	22 700	47	–	–	–	–
		2.91	22 600	47	23 100	48	22 300	46	22 700	47	–	–	–	–
	700	2.42	22 800	41	23 300	41	–	–	–	–	–	–	–	–
		2.91	22 800	41	23 300	41	–	–	–	–	–	–	–	–
	800	2.42	23 100	36	23 600	37	–	–	–	–	–	–	–	–
		2.91	23 100	36	23 600	37	–	–	–	–	–	–	–	–
	900	2.42	23 400	32	23 900	33	–	–	–	–	–	–	–	–
		2.91	23 400	32	23 900	33	–	–	–	–	–	–	–	–
Pad	600	2.42	22 800	47	23 300	48	–	–	–	–	–	–	–	–
		2.91	22 800	47	23 300	48	–	–	–	–	–	–	–	–

\*1 Including 0.80 m<sup>3</sup> (ISO 7451 : 2007 heaped) bucket weight (660 kg) and counterweight (4 850 kg).

\*2 Including 0.80 m<sup>3</sup> (ISO 7451 : 2007 heaped) bucket weight (660 kg) and counterweight (4 700 kg).

\*3 Including 0.80 m<sup>3</sup> (ISO 7451 : 2007 heaped) bucket weight (660 kg) and counterweight (4 700 kg).

## BASIC MACHINE WEIGHT AND COMPONENTS WEIGHT

### Basic Machine Weight and Overall Width

Excluding front end attachment, fuel, hydraulic oil and coolant etc. Including counterweight.

Shoe type	Shoe width (mm)	ZX210LC-7		ZX210LCN-7		ZX240N-7	
		Weight (kg)	Overall width (mm)	Weight (kg)	Overall width (mm)	Weight (kg)	Overall width (mm)
Triple grouser	500	–	–	17 500	2 500	–	–
	550	–	–	–	–	18 300	2 500
	600	17 900	2 990	17 700	2 600	–	–
	700	18 100	3 090	–	–	–	–
	800	18 400	3 190	–	–	–	–
	900	18 700	3 290	–	–	–	–
Pad shoe	600	18 100	2 990	–	–	–	–

### Components Weight

Unit: kg

	ZX210LC-7	ZX210LCN-7	ZX240N-7
Counterweight	4 850	4 700	4 700
Monoblock boom (with arm cylinder and boom cylinder)	2 310	2 310	2 310
2-Piece boom (with arm cylinder and boom cylinder)	2 990	2 990	2 990
Arm 2.42 m (with bucket cylinder)	1 030	1 030	1 030
Arm 2.91 m (with bucket cylinder)	1 080	1 080	1 080
Bucket ISO 7451 : 2007 0.80 m <sup>3</sup>	660	660	660

## BUCKET AND ARM DIGGING FORCE

Unit: kN

Arm length	ZX210LC-7 / ZX210LCN-7		ZX240N-7	
	2.42 m	2.91 m	2.42 m	2.91 m
Bucket digging force* ISO 6015 : 2006	158	158	158	158
Arm crowd force* ISO 6015 : 2006	140	114	140	114

\* At power boost

# SPECIFICATIONS

## ZX210LC-7 / ZX210LCN-7

### DIMENSIONS

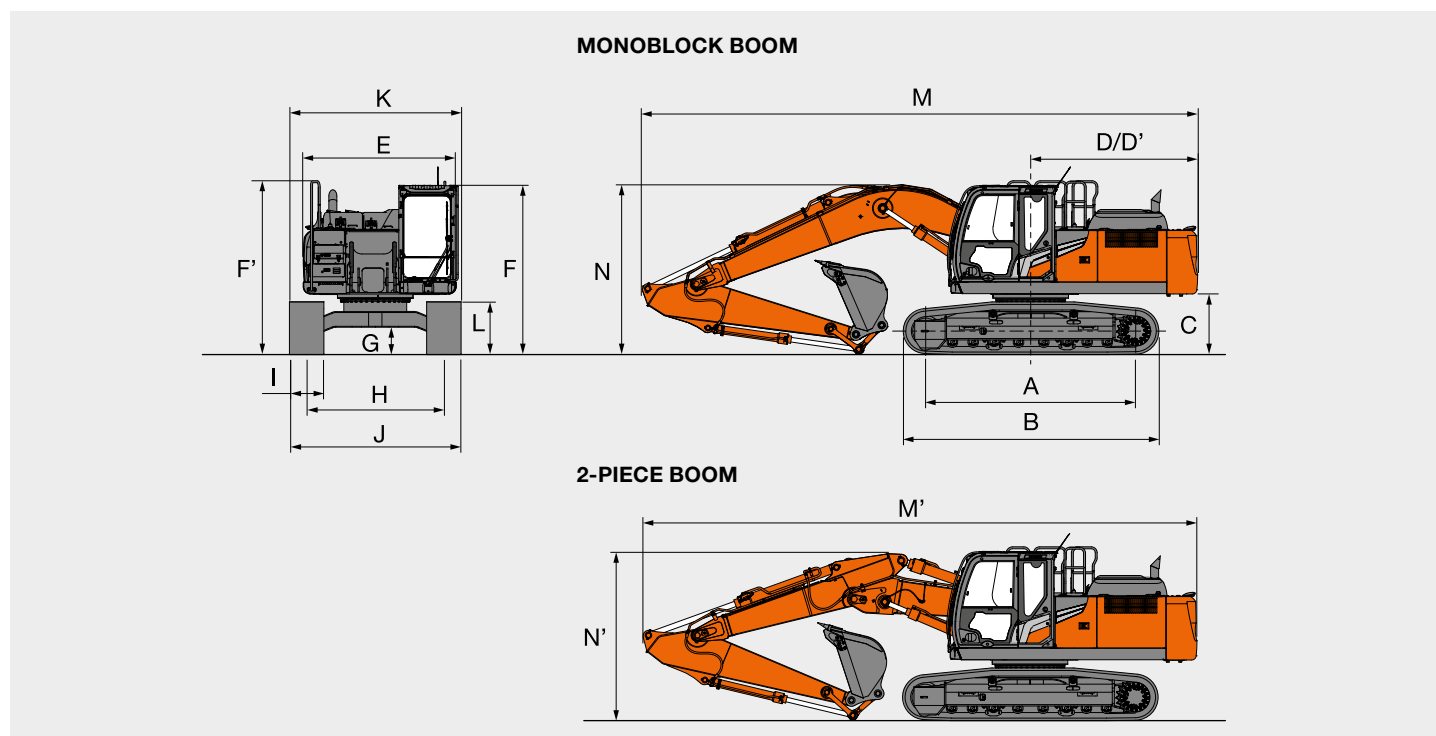

Unit: mm

	ZX210LC-7	ZX210LCN-7
A Distance between tumbler	3 660	3 660
B Undercarriage length	4 450	4 450
* C Counterweight clearance	990	980
D Rear-end swing radius	2 910	2 890
D' Rear-end length	2 910	2 890
E Overall width of upperstructure	2 700	2 480
F Overall height of cab	2 950	2 950
F' Overall height of handrail	3 030	3 030
* G Min. ground clearance	450	450
H Track gauge	2 390	1 980
I Track shoe width	G 600	G 500
J Undercarriage width	2 990	2 480
K Overall width	2 990	2 500
* L Track height with triple grouser shoes	900	900
<b>MONOBLOCK BOOM</b>		
M Overall length		
With arm 2.42 m	9 770	9 740
With arm 2.91 m	9 670	9 650
N Overall height of boom		
With arm 2.42 m	3 200	3 200
With arm 2.91 m	3 000	3 000
<b>2-PIECE BOOM</b>		
M' Overall length		
With arm 2.42 m	9 700	9 680
With arm 2.91 m	9 650	9 630
N' Overall height of boom		
With arm 2.42 m	3 060	3 060
With arm 2.91 m	2 910	2 910

\* Excluding track shoe lug      G: Triple Grouser shoe

# SPECIFICATIONS

## ZX210LC-7 / ZX210LCN-7

### WORKING RANGES

#### MONOBLOCK BOOM

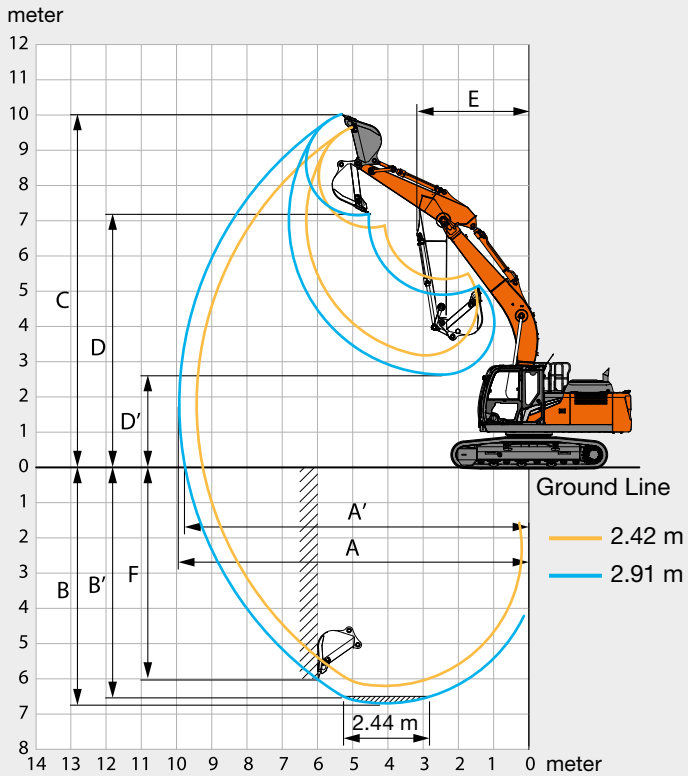

#### 2-PIECE BOOM

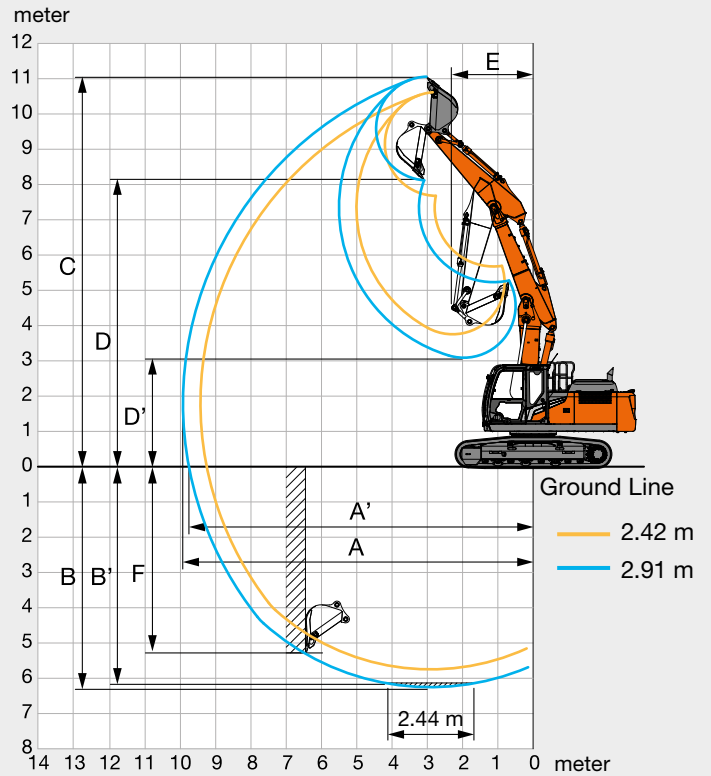

Unit: mm

	ZX210LC-7 / ZX210LCN-7		ZX210LC-7 / ZX210LCN-7	
	Monoblock boom		2-Piece boom	
Arm length	2.42 m	2.91 m	2.42 m	2.91 m
A Max. digging reach	9 430	9 920	9 430	9 930
A' Max. digging reach (on ground)	9 250	9 750	9 250	9 750
B Max. digging depth	6 180	6 670	5 720	6 230
B' Max. digging depth for 2.44 m level	5 950	6 480	5 610	6 120
C Max. cutting height	9 670	10 040	10 640	11 080
D Max. dumping height	6 830	7 180	7 700	8 150
D' Min. dumping height	3 200	2 650	3 780	3 110
E Min. swing radius	3 280	3 180	2 630	2 320
F Max. vertical wall digging depth	5 300	5 990	4 720	5 280

Excluding track shoe lug

# SPECIFICATIONS

## ZX240N-7

### DIMENSIONS

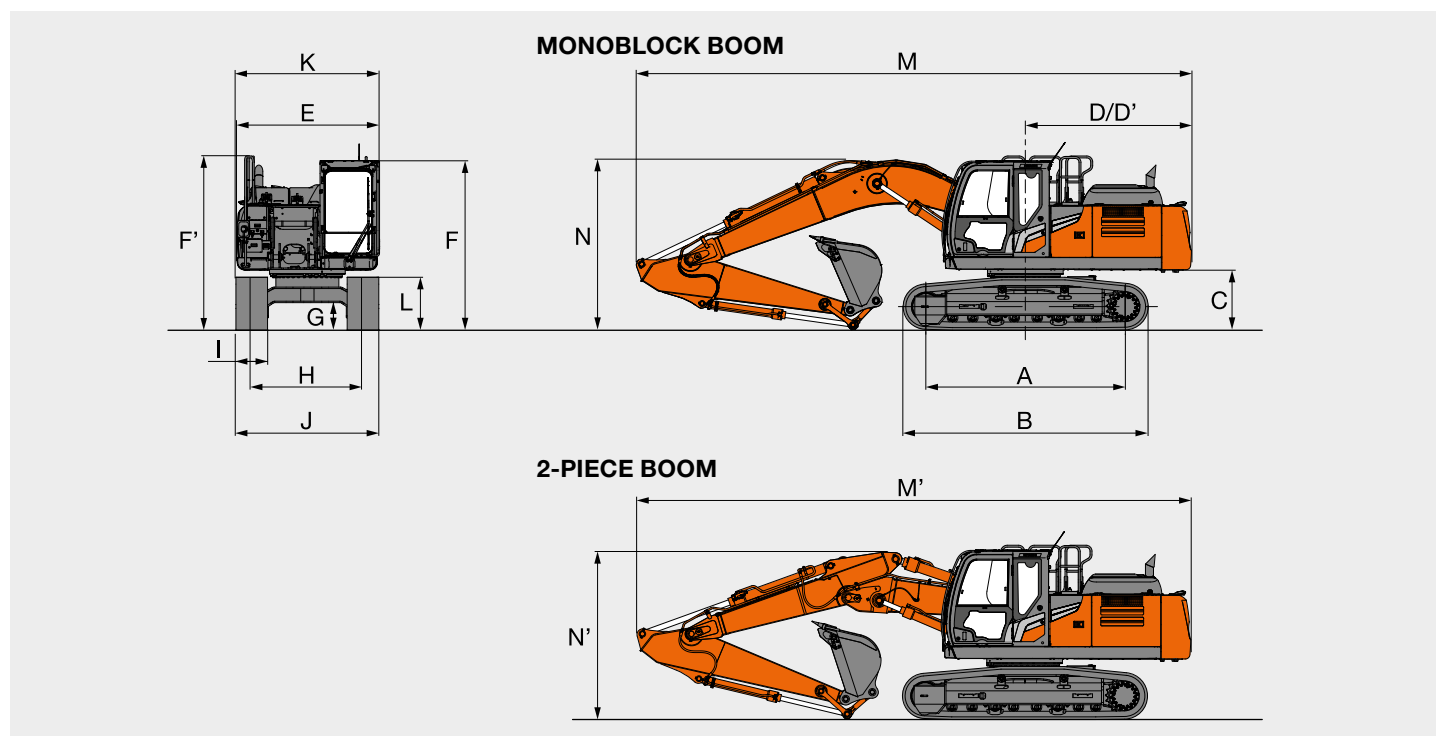

Unit: mm

	ZX240N-7
A Distance between tumbler	3 460
B Undercarriage length	4 260
* C Counterweight clearance	980
D Rear-end swing radius	2 890
D' Rear-end length	2 890
E Overall width of upperstructure	2 480
F Overall height of cab	2 950
F' Overall Height of Handrail	3 030
* G Min. ground clearance	450
H Track gauge	1 980
I Track shoe width	G 550
J Undercarriage width	2 480
K Overall width	2 500
* L Track height with triple grouser shoes	900
<b>MONOBLOCK BOOM</b>	
M Overall length	
With arm 2.42 m	9 740
With arm 2.91 m	9 650
N Overall height of boom	
With arm 2.42 m	3 200
With arm 2.91 m	3 000
<b>2-PIECE BOOM</b>	
M' Overall length	
With arm 2.42 m	9 680
With arm 2.91 m	9 630
N' Overall height of boom	
With arm 2.42 m	3 060
With arm 2.91 m	2 910

\*C, G, L: Excluding track shoe lug      G: Triple Grouser shoe

# SPECIFICATIONS

## ZX240N-7

### WORKING RANGES

#### MONOBLOCK BOOM

meter

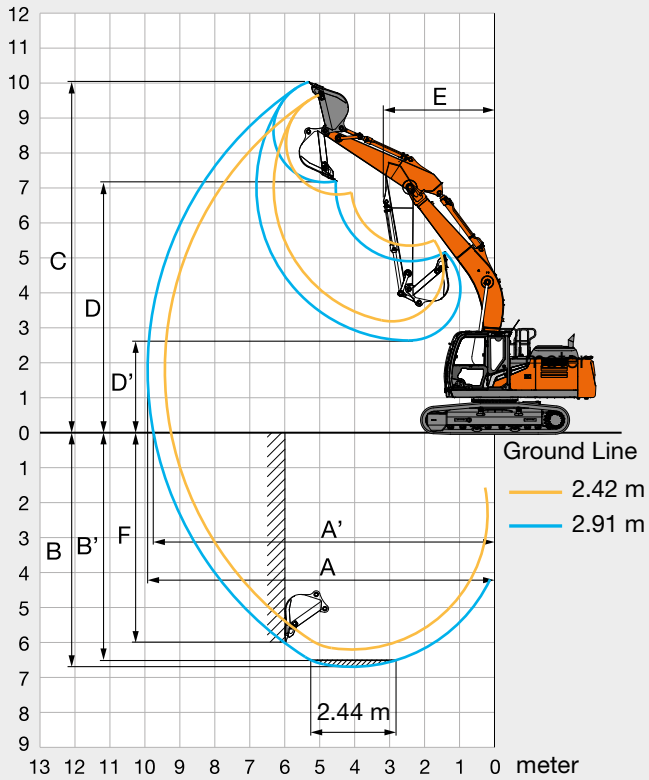

#### 2-PIECE BOOM

meter

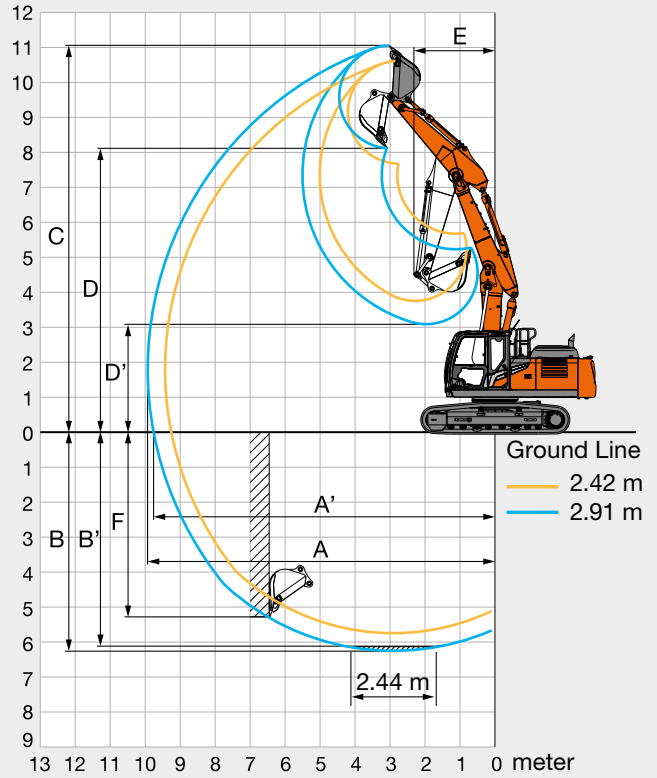

Unit: mm

	ZX240N-7			
	Monoblock boom		2-Piece boom	
Arm length	2.42 m	2.91 m	2.42 m	2.91 m
A Max. digging reach	9 430	9 920	9 430	9 930
A' Max. digging reach (on ground)	9 250	9 750	9 250	9 750
B Max. digging depth	6 180	6 670	5 720	6 230
B' Max. digging depth for 2.44 m level	5 950	6 480	5 610	6 120
C Max. cutting height	9 670	10 040	10 640	11 080
D Max. dumping height	6 830	7 180	7 700	8 150
D' Min. dumping height	3 200	2 650	3 780	3 110
E Min. swing radius	3 280	3 180	2 630	2 320
F Max. vertical wall digging depth	5 300	5 990	4 720	5 280

Excluding track shoe lug

# MACHINE CAPACITIES

## ZX210LC-7 / ZX210LCN-7

- Notes: 1. Ratings are based on ISO 10567 : 2007.  
 2. Machine capacity does not exceed 75% of tipping load with the machine on firm, level ground or 87% full hydraulic capacity.  
 3. The load point is the center-line of the bucket pivot mounting pin on the arm.  
 4. \*Indicates load limited by hydraulic capacity.  
 5. 0 m = Ground.

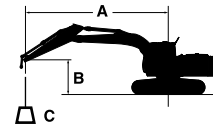

- A: Load radius  
 B: Load point height  
 C: Machine capacity

For machine capacities, subtract installed attachment and quick hitch weight from machine capacities.

To determine lifting capacities, apply "Rating over-side or 360 degrees" machine capacities from the table and deduct weight of installed attachment and quick hitch. Optional feature may affect machine performance.

### ZX210LC-7 MONOBLOCK BOOM

Rating over-front Rating over-side or 360 degrees Unit : kg



Conditions	Load point height m	Load radius										At max. reach		
		1.5 m		3.0 m		4.5 m		6.0 m		7.5 m				meter
Boom 5.68 m Arm 2.42 m Counterweight 4 850 kg	6.0							*5 690	*5 690			*5 720	4 930	6.74
	4.5					*7 270	*7 270	*6 160	5 800			*5 740	4 130	7.48
	3.0					*9 120	8 380	*6 960	5 560	*5 980	4 030	5 650	3 750	7.87
	1.5					*10 610	7 910	*7 720	5 340	5 970	3 930	5 480	3 620	7.95
	0 (Ground)					*11 120	7 710	8 130	5 190	5 890	3 860	5 640	3 700	7.74
	-1.5			*9 880	*9 880	*10 780	7 690	*8 030	5 150			6 220	4 060	7.21
	-3.0			*13 060	*13 060	*9 610	7 800	*7 060	5 230			*6 580	4 940	6.28
-4.5					*6 770	*6 770					*6 340	*6 340	4.71	
Boom 5.68 m Arm 2.91 m Counterweight 4 850 kg	6.0							*5 170	*5 170			*4 000	*4 000	7.32
	4.5					*6 550	*6 550	*5 710	*5 710	*5 320	4 150	*3 950	3 730	8.01
	3.0					*8 440	*8 440	*6 570	5 610	*5 680	4 050	*4 060	3 420	8.37
	1.5					*10 150	8 010	*7 430	5 360	5 970	3 920	*4 330	3 310	8.45
	0 (Ground)			*4 810	*4 810	*11 000	7 730	*8 000	5 190	5 870	3 830	*4 840	3 370	8.25
	-1.5	*5 440	*5 440	*9 070	*9 070	*10 960	7 640	8 050	5 110	5 840	3 800	5 580	3 650	7.76
	-3.0	*9 930	*9 930	*14 220	*14 220	*10 100	7 710	*7 490	5 140			*6 150	4 300	6.90
-4.5			*11 090	*11 090	*8 000	7 930					*6 150	5 980	5.52	













### ZX210LCN-7 MONOBLOCK BOOM

Rating over-front Rating over-side or 360 degrees Unit : kg



Conditions	Load point height m	Load radius										At max. reach		
		1.5 m		3.0 m		4.5 m		6.0 m		7.5 m				meter
Boom 5.68 m Arm 2.42 m Counterweight 4 700 kg	6.0							*5 690	4 920			*5 720	4 070	6.74
	4.5					*7 270	*7 270	*6 160	4 770			*5 740	3 390	7.48
	3.0					*9 120	6 750	*6 960	4 540	5 910	3 290	5 490	3 060	7.87
	1.5					*10 610	6 310	*7 720	4 330	5 800	3 200	5 320	2 940	7.95
	0 (Ground)					*11 120	6 120	7 900	4 190	5 720	3 130	5 470	3 010	7.74
	-1.5			*9 880	*9 880	*10 780	6 100	7 850	4 150			6 040	3 290	7.21
	-3.0			*13 060	11 510	*9 610	6 200	*7 060	4 230			*6 580	4 000	6.28
-4.5					*6 770	6 490					*6 340	6 110	4.71	
Boom 5.68 m Arm 2.91 m Counterweight 4 700 kg	6.0							*5 170	4 990			*4 000	3 590	7.32
	4.5					*6 550	*6 550	*5 710	4 830	*5 320	3 410	*3 950	3 060	8.01
	3.0					*8 440	6 890	*6 570	4 590	*5 680	3 310	*4 060	2 790	8.37
	1.5					*10 150	6 400	*7 430	4 350	5 800	3 190	*4 330	2 690	8.45
	0 (Ground)			*4 810	*4 810	*11 000	6 130	7 900	4 180	5 700	3 100	*4 840	2 730	8.25
	-1.5	*5 440	*5 440	*9 070	*9 070	*10 960	6 060	7 810	4 110	5 670	3 080	5 410	2 950	7.76
	-3.0	*9 930	*9 930	*14 220	11 340	*10 100	6 120	*7 490	4 140			*6 150	3 480	6.90
-4.5			*11 090	*11 090	*8 000	6 320					*6 150	4 830	5.52	













**ZX210LC-7 2-PIECE BOOM**

 Rating over-front  Rating over-side or 360 degrees Unit : kg

Conditions	Load point height m	Load radius										At max. reach		
		1.5 m		3.0 m		4.5 m		6.0 m		7.5 m				meter
														
2-Piece Boom Arm 2.42 m Counterweight 4 850 kg	9.0			*9 060	*9 060							*8 670	*8 670	3.19
	7.5					*6 890	*6 890					*5 860	*5 860	5.50
	6.0					*6 960	*6 960	*5 760	*5 760			*4 930	4 920	6.74
	4.5			*12 120	*12 120	*7 880	*7 880	*6 020	5 950			*4 550	4 110	7.48
	3.0			*13 650	*13 650	*10 050	*8 770	*6 680	5 850	*5 280	4 060	*4 440	3 730	7.87
	1.5			*15 330	*15 330	*11 030	8 590	*7 620	*5 710	*5 650	3 960	*4 540	3 600	7.95
	0 (Ground)	*12 310	*12 310	*17 070	15 890	*11 050	8 450	*8 120	5 470	*5 820	3 860	*4 860	3 690	7.74
	-1.5	*18 380	*18 380	*17 440	15 480	*11 200	8 140	*8 110	5 260			*5 470	4 050	7.21
	-3.0	*24 580	*24 580	*16 690	15 410	*10 320	7 930	*5 900	5 240			*4 900	*4 900	6.25
2-Piece Boom Arm 2.91 m Counterweight 4 850 kg	9.0											*5 390	*5 390	4.30
	7.5					*6 050	*6 050	*5 030	*5 030			*4 390	*4 390	6.20
	6.0					*6 230	*6 230	*5 390	*5 390			*4 060	*4 060	7.32
	4.5			*8 200	*8 200	*7 270	*7 270	*5 670	*5 670	*4 740	4 210	*3 970	3 710	8.01
	3.0	*10 950	*10 950	*14 230	*14 230	*9 120	8 780	*6 290	*5 850	*4 990	4 150	*3 960	3 400	8.37
	1.5	*8 800	*8 800	*14 840	*14 840	*10 840	8 620	*7 210	5 710	*5 370	4 030	*4 040	3 290	8.45
	0 (Ground)	*11 140	*11 140	*16 520	15 770	*11 000	8 560	*8 070	5 570	*5 810	3 890	*4 290	3 350	8.25
	-1.5	*15 120	*15 120	*17 280	15 550	*11 070	8 190	*8 150	5 310	*5 840	3 810	*4 800	3 640	7.76
	-3.0	*19 180	*19 180	*17 350	15 400	*10 970	7 930	*7 270	5 190			*4 650	4 300	6.91
-4.5	*20 940	*20 940	*12 790	*12 790	*7 150	*7 150					*6 960	*6 960	4.57	

**ZX210LCN-7 2-PIECE BOOM**

 Rating over-front  Rating over-side or 360 degrees Unit : kg

Conditions	Load point height m	Load radius										At max. reach		
		1.5 m		3.0 m		4.5 m		6.0 m		7.5 m				meter
														
2-Piece Boom Arm 2.42 m Counterweight 4 700 kg	9.0			*9 060	*9 060							*8 670	*8 670	3.19
	7.5					*6 890	*6 890					*5 860	5 630	5.50
	6.0					*6 960	*6 960	*5 760	5 030			*4 930	4 040	6.74
	4.5			*12 120	*12 120	*7 880	7 560	*6 020	5 050			*4 550	3 360	7.48
	3.0			*13 650	*12 980	*10 050	7 360	*6 680	4 910	*5 280	3 310	*4 440	3 030	7.87
	1.5			*15 330	12 900	*11 030	7 270	*7 620	4 690	*5 650	3 220	*4 540	2 910	7.95
	0 (Ground)	*12 310	*12 310	*17 070	12 190	*11 050	6 790	*8 090	4 430	5 770	3 120	*4 860	2 970	7.74
	-1.5	*18 380	*18 380	*17 440	11 800	*11 200	6 500	8 050	4 240			*5 470	3 270	7.21
	-3.0	*24 580	*24 580	*16 690	11 740	*10 320	6 300	*5 900	4 220			*4 900	4 010	6.25
2-Piece Boom Arm 2.91 m Counterweight 4 700 kg	9.0											*5 390	*5 390	4.30
	7.5					*6 050	*6 050	*5 030	4 990			*4 390	*4 390	6.20
	6.0					*6 230	*6 230	*5 390	5 160			*4 060	3 570	7.32
	4.5			*8 200	*8 200	*7 270	*7 270	*5 670	5 080	*4 740	3 450	*3 970	3 030	8.01
	3.0	*10 950	*10 950	*14 230	13 060	*9 120	7 400	*6 290	4 940	*4 990	3 400	*3 960	2 760	8.37
	1.5	*8 800	*8 800	*14 840	*12 880	*10 840	7 140	*7 210	4 780	*5 370	3 280	*4 040	2 650	8.45
	0 (Ground)	*11 140	*11 140	*16 520	12 440	*11 000	6 890	8 030	4 530	5 800	3 150	*4 290	2 700	8.25
	-1.5	*15 120	*15 120	*17 280	11 860	*11 070	6 540	*8 090	4 280	5 720	3 060	*4 800	2 930	7.76
	-3.0	*19 180	*19 180	*17 350	11 730	*10 970	6 300	*7 270	4 170			*4 650	3 460	6.91
-4.5	*20 940	*20 940	*12 790	11 760	*7 150	6 340					*6 960	6 200	4.57	

# MACHINE CAPACITIES

## ZX240N-7

- Notes: 1. Ratings are based on ISO 10567 : 2007.  
 2. Machine capacity does not exceed 75% of tipping load with the machine on firm, level ground or 87% full hydraulic capacity.  
 3. The load point is the center line of the bucket pivot mounting pin on the arm.  
 4. \*Indicates load limited by hydraulic capacity.  
 5. 0 m = Ground.

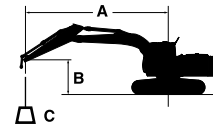

- A: Load radius  
 B: Load point height  
 C: Machine capacity

For machine capacities, subtract installed attachment and quick hitch weight from machine capacities.

To determine lifting capacities, apply "Rating over side or 360 degrees" machine capacities from the table and deduct weight of installed attachment and quick hitch. Optional feature may affect machine performance.

### ZX240N-7 MONOBLOCK BOOM

Rating over-front Rating over-side or 360 degrees Unit : kg

Conditions	Load point height m	Load radius										At max. reach			
		1.5 m		3.0 m		4.5 m		6.0 m		7.5 m				meter	
Boom 5.68 m Arm 2.42 m Counterweight 4 700 kg	6.0							*5 690	5 080			*5 720	4 200	6.74	
	4.5					*7 270	*7 270	*6 160	4 930			*5 740	3 510	7.48	
	3.0					*9 120	6 980	*6 960	4 700	5 740	3 410	5 340	3 180	7.87	
	1.5					*10 610	6 540	*7 720	4 480	5 630	3 320	5 180	3 060	7.95	
	0 (Ground)					*11 120	6 350	7 630	4 340	5 560	3 250	5 320	3 120	7.74	
	-1.5			*9 880	*9 880	*10 780	6 330	7 580	4 300				5 860	3 420	7.21
	-3.0			*13 060	11 910	*9 610	6 430	*7 060	4 380				*6 580	4 150	6.28
-4.5					*6 770	6 720						*6 340	6 320	4.71	
Boom 5.68 m Arm 2.91 m Counterweight 4 700 kg	6.0							*5 170	5 150			*4 000	3 720	7.32	
	4.5					*6 550	*6 550	*5 710	4 990	*5 320	3 530	*3 950	3 170	8.01	
	3.0					*8 440	7 120	*6 570	4 750	*5 680	3 430	*4 060	2 890	8.37	
	1.5					*10 150	6 630	*7 430	4 510	5 630	3 310	*4 330	2 790	8.45	
	0 (Ground)			*4 810	*4 810	*11 000	6 360	7 630	4 340	5 530	3 220	*4 840	2 840	8.25	
	-1.5	*5 440	*5 440	*9 070	*9 070	*10 960	6 280	7 540	4 260	5 500	3 200	5 260	3 070	7.76	
	-3.0	*9 930	*9 930	*14 220	11 750	*10 100	6 340	*7 490	4 300			*6 150	3 610	6.90	
-4.5			*11 090	*11 090	*8 000	6 550					*6 150	5 000	5.52		

### ZX240N-7 2-PIECE BOOM

Rating over-front Rating over-side or 360 degrees Unit : kg

Conditions	Load point height m	Load radius										At max. reach		
		1.5 m		3.0 m		4.5 m		6.0 m		7.5 m				meter
2-Piece Boom Arm 2.42 m Counterweight 4 700 kg	9.0			*9 060	*9 060							*8 670	*8 670	3.19
	7.5					*6 890	*6 890					*5 860	5 810	5.50
	6.0					*6 960	*6 960	*5 760	5 190			*4 930	4 180	6.74
	4.5			*12 120	*12 120	*7 880	*7 740	*6 020	5 190			*4 550	3 480	7.48
	3.0			*13 650	13 300	*10 050	7 550	*6 680	5 060	*5 280	3 430	*4 440	3 140	7.87
	1.5			*15 330	13 220	*11 030	7 490	*7 620	4 850	*5 650	3 340	*4 540	3 020	7.95
	0 (Ground)	*12 310	*12 310	*17 070	12 600	*11 050	7 020	7 880	4 590	5 600	3 240	*4 860	3 090	7.74
	-1.5	*18 380	*18 380	*17 440	12 200	*11 200	6 730	7 760	4 390			*5 470	3 390	7.21
-3.0	*24 580	*24 580	*16 690	12 140	*10 320	6 530	*5 900	4 380			*4 900	4 160	6.25	
2-Piece Boom Arm 2.91 m Counterweight 4 700 kg	9.0											*5 390	*5 390	4.30
	7.5					*6 050	*6 050	*5 030	*5 030			*4 390	*4 390	6.20
	6.0					*6 230	*6 230	*5 390	5 290			*4 060	3 690	7.32
	4.5			*8 200	*8 200	*7 270	*7 270	*5 670	5 220	*4 740	3 570	*3 970	3 140	8.01
	3.0	*10 950	*10 950	*14 230	*13 370	*9 120	7 590	*6 290	5 080	*4 990	3 520	*3 960	2 860	8.37
	1.5	*8 800	*8 800	*14 840	13 190	*10 840	7 340	*7 210	4 920	*5 370	3 400	*4 040	2 760	8.45
	0 (Ground)	*11 140	*11 140	*16 520	12 840	*11 000	7 110	7 840	4 690	5 630	3 270	*4 290	2 810	8.25
	-1.5	*15 120	*15 120	*17 280	12 260	*11 070	6 770	7 810	4 430	5 540	3 180	*4 800	3 040	7.76
	-3.0	*19 180	*19 180	*17 350	12 130	*10 970	6 530	*7 270	4 320			*4 650	3 600	6.91
-4.5	*20 940	*20 940	*12 790	12 160	*7 150	6 560					*6 960	6 420	4.57	





# EQUIPMENT

ENGINE	ZX210LC-7/ ZX210LCN-7	ZX240N-7
Aftertreatment device	●	●
Air cleaner double filters	●	●
Alternator 60 A	●	●
Auto idle system	●	●
Auto shut-down control	●	●
Cartridge-type engine oil filter	●	●
Cartridge-type fuel main filter	●	●
Cold fuel resistance valve	●	●
ConSite OIL (sensor)*	●	●
DEF/AdBlue® tank inlet strainer and extension filler	●	●
DEF/AdBlue® tank	●	●
Dry-type air filter with evacuator valve (with air filter restriction indicator)	●	●
Dust-proof indoor net	●	●
ECO/PWR mode control	●	●
Electrical fuel feed pump	●	●
Engine oil drain coupler	●	●
Expansion tank	●	●
Fan guard	●	●
Fuel cooler	●	●
Fuel pre-filter with water separator	●	●
Isolation-mounted engine	●	●
Maintenance free pre-cleaner	○	○
Radiator, oil cooler and intercooler	●	●

HYDRAULIC SYSTEM		
Auto power lift	●	●
ConSite OIL (sensor)*	●	●
Control valve with main relief valve	●	●
High mesh full flow filter	●	●
Hose rupture valve for arm	●	●
Hose rupture valve for boom	●	●
Pilot filter	●	●
Power boost	●	●
Restriction indicator for full flow filter	○	○
Suction filter	●	●
Swing dampener valve	●	●
Two extra ports for control valve	●	●
Variable reliefvalve for breaker and crusher	●	●
Work mode selector	●	●

CAB	ZX210LC-7/ ZX210LCN-7	ZX240N-7
All-weather sound suppressed steel cab	●	●
Auto control air conditioner	●	●
AUX function lever (breaker assist)	○	○
Bluetooth® integrated DAB+radio	●	●
Cab with P5A glass and roof wiper	○	○
Console height adjustment	●	●
Control lever auto-lock	●	●
CRES VII (center pillar reinforced structure) cab	●	●
Drink holder with hot and cool function	●	●
Electric double horn	●	●
Engine shut-off switch	●	●
Equipped with reinforced, tinted (green color) glass windows	●	●
Evacuation hammer	●	●
Floor mat	●	●
Footrest	●	●
Front window washer (2 points)	●	●
Glove compartment	●	●
Hands-free calling device	●	●
Hot and cool box	●	●
Intermittent windshield wipers	●	●
Key cylinder light	●	●
Laminated round glass window	○	○
LED room light	●	●
Magazine rack	●	●
OPG front guard Level II (ISO 10262 : 1998) compliant	○	○
OPG top guard Level I (ISO 10262 : 1998) compliant	●	●
OPG top guard Level II (ISO 10262 : 1998) compliant	○	○
Pilot shut-off lever	●	●
Power outlet 12 V and 24 V	●	●
Push button low idle	●	●
Rain guard (without OPG front guard)	●	●
Rear tray	●	●
Retractable seat belt	●	●
ROPS (ISO 12117-2 : 2008) compliant cab	●	●
Rubber radio antenna	●	●
Seat : air suspension seat with heater	●	●
Seat adjustment part : backrest, armrest, height and angle, slide forward / back	●	●
Seat belt reminder	●	●
Short wrist control levers	●	●
Sunscreen roller type (multi-use front or side and rear window)	○	○
Smartphone holder	●	●
Transparent roof with slide curtain	●	●
Wide view wiper	●	●
Windows on front, upper, lower and left side can be opened	●	●
2 speakers	●	●
4 fluid-filled elastic mounts	●	●
5V to USB power supply	●	●
8 inch monitor	●	●

● : Standard equipment    ○ : Optional equipment

MONITOR SYSTEM	ZX210LC-7/ ZX210LCN-7	ZX240N-7
Alarms: overheat, engine warning, engine oil pressure, alternator, minimum fuel level, hydraulic filter restriction, air filter restriction, work mode, overload, SCR system trouble, etc	●	●
Alarm buzzers: overheat, engine oil pressure, overload, SCR system trouble, etc	●	●
Display of meters: water temperature, hour, fuel rate, clock, DEF/ AdBlue® rate, etc	●	●
Other displays:work mode, auto-idle, glow, rearview monitor, operating conditions, etc	●	●
35 languages selection	●	●

LIGHTS		
Additional boom LED light with cover	○	○
Additional cab roof front LED lights	○	○
Additional cab roof rear LED light	○	○
LED lights for camera (side and rear view camera)	○	○
Rotating lamp	○	○
2 working LED lights	●	●

UPPER STRUCTURE		
Aerial Angle® (270-degree view camera system)	●	●
Batteries 2 x 126 Ah	●	●
Battery disconnect switch	●	●
Body top handrail	●	●
Counterweight 4 850 kg	● / -	-
Counterweight 4 700 kg	- / ●	●
Electric fuel refilling pump with auto stop and filter	●	●
Fuel level float	●	●
Hydraulic oil level gauge	●	●
Lockable fuel refilling cap	●	●
Lockable machine covers	●	●
Lockable tool box	●	●
Platform handrail	●	●
Side view mirror (right and left)	●	●
Skid-resistant plates	●	●
Swing parking brake	●	●
Undercover	●	-
Reinforced undercover	-	●
Utility space	●	●

UNDERCARRIAGE	ZX210LC-7/ ZX210LCN-7	ZX240N-7
Bolt-on sprocket	●	●
Greasing type track adjuster	●	●
Lockable tool box	- / ●	●
Reinforced track links with pin seals	●	●
Shoe: 500 mm triple grouser	- / ●	-
Shoe: 550 mm triple grouser	-	●
Shoe: 600 mm triple grouser	● / -	-
Shoe: 600 mm pad crawler	● / ○	-
Shoe: 700, 800 900 mm triple grouser	○ / -	-
Towing hole for light weight object	●	●
Track undercover	●	●
Travel direction mark on track frame	●	●
Travel motor covers	●	●
Travel parking brake	●	●
Upper and lower rollers	●	●
2 track guards (each side)	●	●
3 track guards (each side)	○	-
4 tie down brackets	●	●

FRONT ATTACHMENTS		
Arm tip remote lubrication	●	●
Casted bucket link A	●	●
Centralized lubrication system	●	●
Dirt seal on all bucket pins	●	●
Flanged pin	●	●
HN bushing	●	●
Lower arm reinforcement	○	○
Reinforced bucket link B	●	●
Reinforced resin thrust plate	●	●
WC (tungsten-carbide) thermal spraying	●	●
Welded bucket link A	○	○
Welded bucket link A with welded hook	○	○

ATTACHMENTS		
Accessories for 2 speed selector	○ / ●	●
Additional pump	○	○
Assist piping	○	○
Breaker and crusher piping	c	●
Pilot accumulator	●	●

MISCELLANEOUS		
ConSite	○	○
Global e-Service	●	●
Onboard information controller	●	●
Standard tool kit	●	●

Standard and optional equipment may vary by country, so please consult your Hitachi dealer for details.  
\* Engine oil and hydraulic oil monitoring sensor.

Prior to operating this machine, including satellite communication system, in a country other than a country of its intended use, it may be necessary to make modifications to it so that it complies with the local regulatory standards (including safety standards) and legal requirements of that particular country. Please do not export or operate this machine outside the country of its intended use until such compliance has been confirmed. Please contact your Hitachi dealer in case of questions about compliance.

These specifications are subject to change without notice. Illustrations and photos show the standard models, and may or may not include optional equipment, accessories, and all standard equipment with some differences in color and features. Before use, read and understand the Operator's Manual for proper operation.

